

ASAP FASTENING SYSTEMS, INC.

SUPPLIES FOR INDUSTRY AND CONSTRUCTION

2013 SOUTH 37TH STREET • MILWAUKEE, WISCONSIN 53215

(414) 344-4500 • FAX (414) 344-4504

WWW.ASAPFASTENING.COM • EMAIL: SALES@ASAPFASTENING.COM

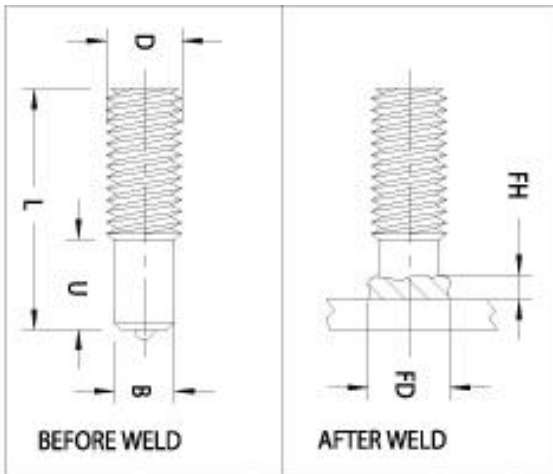

TYPE TP STUD

THREADED - PITCH DIAMETER WELD BASE

TYPE P FERRULE SUPPLIED

(NOTE #3)

BEFORE WELD		AFTER WELD				LIGHT DUTY STANDARD		LIGHT DUTY SPLIT		STANDARD COMBINATION ^{*4}		
D DIAMETER AND THREAD	L ^{*1} MIN. LENGTH BEFORE WELD	STUD PART NUMBER ^{*2}	B	U	FD WELD FILLET DIAMETER	FH WELD FILLET HEIGHT	CHUCK PART NUMBER	FOOT PART NUMBER	GRIP PART NUMBER	FOOT PART NUMBER	GRIP PART NUMBER	FOOT AND GRIP
1/4-20	3/4	1311-04-012	.215	3/8	5/16	3/32	5017	11121	8011	11124	8024	8121
5/16-18	3/4	1311-05-012	.275	3/8	13/32	7/64	5018	11121	8012	11124	8025	8122
3/8-16	3/4	1311-06-012	.330	13/32	7/16	7/64	5019	11121	8013	11124	8050	8123
7/16-14	7/8	1311-07-014	.387	7/16	1/2	1/8	8026	11121	8014	11124	8051	8124
1/2-13	7/8	1311-08-014	.448	1/2	19/32	5/32	8027	11121	8015	11124	8052	8125
5/8-11	1	1311-10-016	.562	5/8	3/4	3/16	8028	11122	8016	11125	8053	8126
3/4-10	1-3/16	1311-12-019	.680	13/16	7/8	1/4	8029	11122	8017	11125	8054	8127
7/8-9	1-11/16	1311-14-027	.798	7/8	1	5/16	8030	11123	8018	11126	8055	8128
1-8	1-11/16	1311-16-027	.915	15/16	1-1/8	5/16	8032	11123	8019	11126	8056	8129

1)  STUDS ARE AVAILABLE IN ANY REQUIRED LENGTH ABOVE THE STANDARD MINIMUM. MAXIMUM THREAD LENGTH FOR TP STUDS IS 3 INCHES.

2) SEE PART NUMBER CONSTRUCTION DATA ON PAGE NO.3

3) LISTED FERRULE IS FOR STANDARD FLAT DOWN HAND POSITION. SEE PAGE NO.5 FOR LISTING OF FERRULES USED IN OTHER APPLICATIONS.

4) REQUIRES USE OF P/N-11101 DUAL LEG ADAPTOR.

CONFORMS TO MIL-S-24149(SHIPS)