

ASAP FASTENING SYSTEMS, INC.

SUPPLIES FOR INDUSTRY AND CONSTRUCTION

2013 SOUTH 37TH STREET • MILWAUKEE, WISCONSIN 53215

(414) 344-4500 • FAX (414) 344-4504

WWW.ASAPFASTENING.COM • EMAIL: SALES@ASAPFASTENING.COM

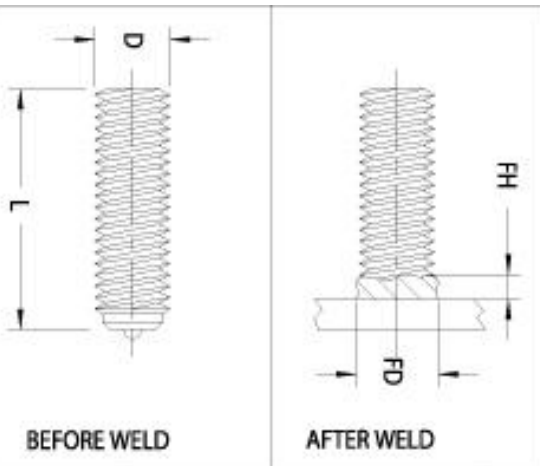

TYPE II STUD
FULLY THREADED - FULL WELD BASE
TYPE F FERRULE SUPPLIED

(NOTE #3)

BEFORE WELD		AFTER WELD				LIGHT DUTY STANDARD		LIGHT DUTY SPLIT		STANDARD COMBINATION ^{*4}
D DIAMETER AND THREAD	L ^{*1} MIN. LENGTH BEFORE WELD	STUD PART NUMBER ^{*2}	FD WELD FILLET DIAMETER	FH WELD FILLET HEIGHT	CHUCK PART NUMBER	FOOT PART NUMBER	GRIP PART NUMBER	FOOT PART NUMBER	GRIP PART NUMBER	FOOT AND GRIP
1/4-20	3/4	1411-04-012	23/64	7/64	5017	11121	8011	11124	8024	8121
5/16-18	3/4	1411-05-012	7/16	7/64	5018	11121	8012	11124	8025	8122
3/8-16	3/4	1411-06-012	1/2	1/8	5019	11121	8015	11124	8052	8125
7/16-14	7/8	1411-07-014	19/32	9/64	8026	11121	8014	11124	8051	8124
1/2-13	7/8	1411-08-014	11/16	5/32	8027	11122	8016	11125	8053	8126
5/8-11	1	1411-10-016	7/8	3/16	8028	11122	8017	11125	8054	8127
3/4-10	1-3/16	1411-12-019	1-1/16	1/4	8029	11122	8017	11125	8054	8127
7/8-9	1-11/16	1411-14-027	1-1/8	5/16	8030	11123	8018	11126	8055	8128
1-8	1-11/16	1411-16-027	1-3/8	3/8	8032	11123	8019	11126	8056	8129

- 1) STUDS ARE AVAILABLE IN ANY REQUIRED LENGTH ABOVE THE STANDARD MINIMUM.
- 2) SEE PART NUMBER CONSTRUCTION DATA ON PAGE NO.3
- 3) LISTED FERRULE IS FOR STANDARD FLAT DOWN HAND POSITION. SEE PAGE NO.5 FOR LISTING OF FERRULES USED IN OTHER APPLICATIONS.
- 4) REQUIRES USE OF PYN-11101 DUAL LEG ADAPTOR.

CONFORMS TO MIL-5-24149(SHIPS)