

ASAP FASTENING SYSTEMS, INC.

SUPPLIES FOR INDUSTRY AND CONSTRUCTION

2013 SOUTH 37TH STREET • MILWAUKEE, WISCONSIN 53215

(414) 344-4500 • FAX (414) 344-4504

WWW.ASAPFASTENING.COM • EMAIL: SALES@ASAPFASTENING.COM

Rivets

Aluminum Rivet/Aluminum Mandrel

Countersunk Head
Blind Rivet

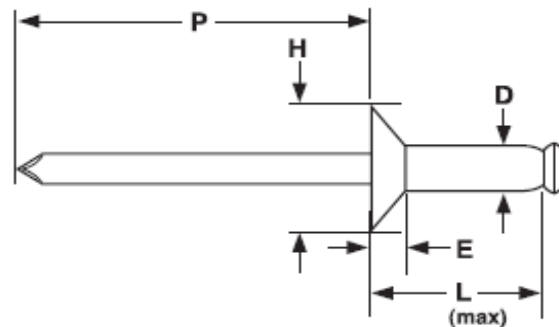

120° COUNTERSUNK HEAD BREAK-STEM BLIND RIVETS

SAE J-1200

Nominal Rivet Diameter	D		H		E	W	P	F
	Rivet Shank Diameter		Head Diameter		Head Height	Mandrel Diameter	Mandrel Protrusion	Blind Side Protrusion
	Max	Min	Max	Min	Max	Nom	Min	Max
1/8	.128	.122	.233	.207	.031	.076	1.00	L + 0.120
5/32	.159	.153	.294	.268	.040	.095	1.06	L + 0.140
3/16	.191	.183	.361	.335	.050	.114	1.06	L + 0.160

Description	An all aluminum blind fastener with a self-contained carbon mandrel which permits the formation of an upset on the blind end of the rivet and expansion of the rivet shank during rivet setting. The mandrel is pulled into or against the rivet body, breaking at or near the junction of the mandrel shank and its upset end. The head of the rivet body is countersunk at an angle of 120°.
Applications/Advantages	The countersunk head style provides a smooth offside surface and sufficient clearance for moving parts which pass over the rivet head. Aluminum rivets are lightweight and resist corrosion, but have lower tensile and shear values than steel or stainless rivets.
Material	Rivet Body: Aluminum alloy 5050 or 5052 or equivalent Mandrel: Aluminum alloy 7178 or 2024 or equivalent
Shear Strength (Min.)	1/8: 120 lbs.; 5/32: 190 lbs.; 3/16: 260 lbs.
Tensile Strength (Min.)	1/8: 150 lbs.; 5/32: 230 lbs.; 3/16: 320 lbs.
Mandrel Break Load	1/8: 250 - 400 lbs.; 5/32: 425 - 600 lbs.; 3/16: 625 - 825 lbs.